



# apollo

## Remote Controlled RF table

### Product Data

#### Movements

Tilting	Motorized, $-90^{\circ}/+90^{\circ}$ , with automatic stop in horizontal position. Two user selectable speeds: 4.5 or 6.5°/s (speed can be changed at installation)
Elevating tabletop	Motorized, max run 68 cm (26.8"). Speed 2,5 cm/s (1 inch/s) (can be changed at installation)
Transversal tabletop movement	Motorized, 32 cm = $\pm 16$ cm (12.6" = $\pm 6.3$ "). Max speed 5 cm/s (2 inches/s) with soft start/stop for maximum patient comfort. Automatic centering
Longitudinal tabletop movement	The complete patient coverage is guaranteed by the large travel of the tube/spot film device assembly, not requiring any longitudinal tabletop movement for the maximum patient comfort and safety
Tube column and spot film device movement	Motorized, 160 cm (63"). The movement starts slowly for accurate adjustments and increases according to an acceleration step to quickly cover long distances. Maximum speed 20 cm/s (7.9 inches/s)
Patient exploration	203 cm (80") (with 35x43 cm cassettes or with 35x43 cm and 43x43 cm wireless detectors) thanks to the movement of the tube/spot film device only, without patient repositioning
Tube column tilting	Motorized, $\pm 40^{\circ}$ . Speed 11°/s (can be customized at installation). Automatic centering of target organ during oblique projections in fluoroscopy. Possibility to perform oblique exposures at both edges of the tabletop. Automatic centering
SID (Source to Image Distance)	Motorized, with continuous adjustment. Two versions are available (to be specified at order): <ul style="list-style-type: none"> <li>• 100 - 150 cm (39.4" - 59")</li> <li>• 110 - 180 cm (43.3" - 70.9")</li> </ul> Upward speed 2,2 cm/s (0.9 inches/s), downward speed 3,0 cm/s (1.2 inches/s)
Tube rotation	Manual $-90^{\circ}/+180^{\circ}$ . Starting from 0° position, the mechanical stops are at $\pm 15^{\circ}$ and $\pm 30^{\circ}$ , then every 10°
Focal spot to floor distance (with table in vertical position)	51,5 - 211,5 cm (20.3"- 83.3") without column tilting



### Flat surface tabletop

Maximum patient weight	Up to 284 kg (627 lbs), without any movement limitations
Dimensions	237,5 x 74 cm (93.5" x 29.1")
Radio-transparent area	235,5 x 55 cm (92.7" x 21.7")
Minimum tabletop height from floor (with standard under-floor installation plate)	65,5 cm (25.8") with 9" I.I. 76,5 cm (30.1") with 12" I.I. 81,5 cm (32.1") with 16" I.I.
Maximum tabletop height from floor (with standard under-floor installation plate)	131,5 cm (51.8")
Surface	Flat, totally smooth without raised edges
Material	Microsandwich: carbon fiber + Rohacell® + HPL
X-ray attenuation	≤ 0.5 mm Al @ 100 kVp, HVL = 3.6 mm Al
Minimum distance between central X-ray beam and tabletop edges	39 cm (15.4") both sides
Skin to Film distance	9,7 cm (3.8") minimum
Skin to I.I. distance	11,6 cm (4.6") minimum

### Flat surface "Open" tabletop (option)

Type	Single side suspended tabletop
Maximum patient weight	Up to 230 kg (507 lbs) distributed along the tabletop length, without any movement limitations
Dimensions	235,5 x 74 cm (93.5" x 29.1")
Radio-transparent area	221 x 55 cm (87" x 21.7")
Minimum tabletop height from floor (with standard under-floor installation plate)	64 cm (25.2") with 9" I.I. 75 cm (29.5") with 12" I.I. 80 cm (31.5") with 16" I.I.
Maximum tabletop height from floor (with standard under-floor installation plate)	130 cm (51.2")
Surface	Flat
Material	Carbon fiber
X-ray attenuation	≤ 0.3 mm Al @ 100 kVp, HVL = 3.6 mm Al
Minimum distance between central X-ray beam and tabletop edges	39 cm (15.4") both sides
Skin to Film distance	8,3 cm (3.3") minimum
Skin to I.I. distance	10,2 cm (4") minimum



## Spot Film Device

Cassette size	13x18 cm to 35x43 cm (5"x7" to 14"x17"). Spot Film Device is compatible with 35x43 cm and 43x43 cm wireless Flat Panel detectors offered by Villa
Divisions	1, 2, 3, 4 in line; 4, 6 in cross. See attached tables. Divisions are not available with optional Multi-Grid system
Internal collimation	Near-film internal shutters for scatter radiation reduction. Not available in combination with optional Multi-Grid system
Rapid sequence	Yes
Minimum fluoro to exposure switching time	0.8 s
Average speed in rapid sequence	2 exposures per second
Cassette loading	Frontal, without external tray. Loading with fully automatic cassette alignment and centering. It is sufficient to insert the cassette into the SFD slot and press the loading button
Cassette ejection	Automatic or manual, depending on the setting
AEC measuring chamber	Predisposed
Grid	Oscillating, synchronized to X-ray start
Grid parking	The grid can be automatically parked out of X-ray field for pediatric and gridless exams. Grid parking is activated by a pushbutton on the console
Multi-Grid system	Option. The Multi-Grid system automatically selects and inserts inside the X-ray field one of two available antiscatter grids, according to the selected SID. Grid features: - Grid 1: f = 120 cm (43") for general rad exams, 12:1, 36 L/cm (91 L/inch) - Grid 2: f = 180 cm (72") for chest exams, 12:1, 36 L/cm (91 L/inch)

## Image intensifier

Available size	9" / 12" / 16"
Parallax correction	Parallax error is negligible due to the very low distance between I.I. and film

## Flat Panel upgrade

Upgradeability	Apollo can be upgraded to Apollo DRF replacing Spot Film Device and Image Intensifier with Dynamic Flat Panel
----------------	---



## Collimator

Interface	2x20 character LCD display
Displayed information	SID, collimation format
Collimation	Square and rectangular (standard) Iris (standard for the USA market, option for other markets)
Number of shutters	6 pairs of shutters, including near-focus shutters
Shutters material	Iron + Lead (Fe + Pb)
Adjustment	Automatic with SID compensation, microprocessor controlled
"Hold" function	The position of the diaphragms set during fluoro can be frozen when switching to exposure
Field coverage	48x48 cm @ SID = 100 cm (18,9"x18,9" @ SID = 39,4")
Collimator filtration	Minimum 2 mm Al eq @ 100 kV, HVL = 3,6 mm Al
Stray radiation	≤ 40 mR/hr @ 150 kVp, 4 mA
Light source	LED source
Additional filtration	Optional, automatic and manual selection. Values of added filtration: 1 mm Al + (1 mm Al or 0,1 mm Cu or 0,2 mm Cu)
Total filtration (tube + housing + collimator)	≥ 2,7 mm Al eq. @ 100 kV
Camera for patient positioning	Option. A colour camera integrated in the collimator allows the live visualization of patient on the table and its positioning without X-ray emission. The images are displayed on touch screen control console
Collimator rotation	A flange allows the ± 90° collimator rotation



## Functions

Movement orientation selection	The movements associated with the joystick for the control of the column longitudinal movement and the transversal tabletop movement can be changed according to the orientation selected by the operator: "monitor view" to coordinate the joystick's movements with the motion of the image displayed on the monitor, and "table view" to coordinate the joystick's movements to the actual table movement
Controls on touch screen console	Table movements, Spot Film Device functions, collimator, tomography, compressor, TV chain
Tableside controls	Table tilting, tabletop transversal and lift, column scanning and tilting, SID adjustment, collimator lamp, cassette loading/unloading
X-ray control	Footswitch for fluoro and rad exposures Pushbutton on remote control console for exposure. Two-steps pushbutton for exposure (option)
Table position memory	Up to three user-defined table positions can be stored, for instance for patient entrance or for most common exams. These positions can be recalled through a dedicated button on the console
Intercom system	The control console is provided with an intercom device allowing operator talking/listening to the patient from the command room, while the patient is placed on the table. Automatic voice messages are available, selectable among 3 languages chosen at installation, for RAD procedures. Available languages: English, French, Spanish, Italian, German, Russian, Arabian, Chinese. Some languages may be available both with male or female voice. Example of set messages: "Take a big breath - Hold your breath", activated during PREP phase; "You can breathe", activated after X-rays go OFF or if PREP and/or RAD command is released
Applications	Fluoroscopy, radiography, tomography, angiography (option with digital system), stitching (option with wireless detector)
Projections	Perpendicular, oblique, on gurneys or wheelchairs, on chest stand (option)
Tomoscopy	The organ remains centered when taking oblique projections during fluoro
Fault indication and memory	Fault conditions are visualized with codes and text messages on the display. An internal memory stores the history of faults and equipment conditions



## Touch screen console

Interface	12" LCD colour touch screen, 800 x 600 pixel, 4:3
Brightness	> 300 cd/m <sup>2</sup>
Contrast	450 : 1
Colours	65.536
Viewing angle	>35° (↑) / >55° (↓) / >60° (←) / >60° (→)
Smart-touch joysticks	Except the joystick for collimator control, the console is equipped with four smart-touch joysticks for control of Apollo's functions and movements. Smart-touch joysticks are activated by human touch to avoid unintentional movements of the equipment
Pushbuttons	Emergency red pushbutton, PREP and RAD pushbuttons for exposure control

## Joysticks on the touch screen console

For Apollo version, the joystick functions are arranged as follows:

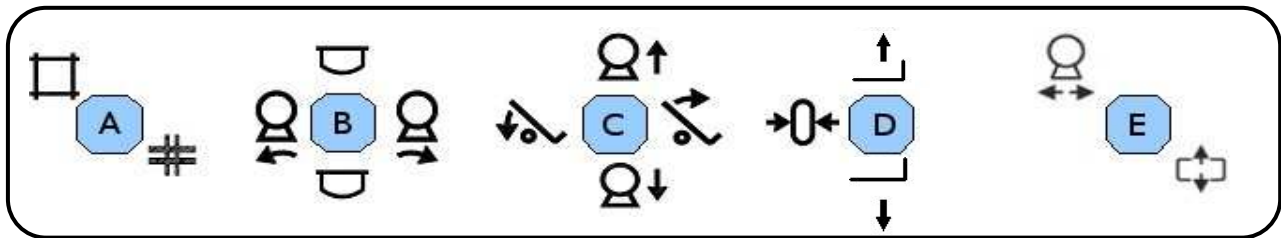

Key	Functions
A	Collimator regulation
B	← → : column tilting ↑ ↓ : compressor movement
C	← → : tabletop tilting ↑ ↓ : SID adjustment
D	← : auto centering ↑ ↓ : tabletop height adjustment
E	← → : column/detector group horizontal movement ↑ ↓ : tabletop transversal movement (can be inverted according to the selected orientation)

Note: A, C and E joysticks have 8-way movement.

## Compressor

Compression	Motorized, remote controlled
Compression force	3 kg (6.6 lbs) to 15 kg (33,1 lbs) step 0.5 kg (1,1 lbs)
Useful distance between compressor and tabletop	10 ÷ 35 cm (3.9" ÷ 13.8") for standard tabletop 11,5 ÷ 36,5 cm (4.5" ÷ 14.4") for Open tabletop
Compression cone	Removable, made of radiotransparent plastic
Compressor parking	When not in use, the compressor is automatically parked behind the tube for maximum patient safety
Securities	Both software and hardware securities. Quick unhook in case of blackout



## Tomography

Tomographic technique	Linear tomography with arc-plane movement, fully electronic (without connection bar)				
Table positions	Tomography can be performed in every table position				
Angles	7°, 20°, 30°, 45°				
Speeds	4 speeds, from 11.2 to 22.4°/s (can be changed at installation)				
Direction	Bi-directional, left-right or viceversa, user selected				
Layer height	Electronic adjustment 0 ÷ 350 mm, 1 mm step (0 ÷ 13,8", 0,04" step)				
Automatic layer height increase	The layer height can be automatically increased for each exposure when a multiple division is selected				
Automatic sequences	Sequences of tomo images with automatic layer position increase and bi-directional movement, without stopping the movement between exposures				
Source to Image Distance	114 cm (44.9")				
Alternate images	Regular exposures and tomographic exposures can be taken on the same film				
Approx. layer thickness @ height =125 mm	7° = 25 mm (1"), 30° = 10 mm (0,4"),		20° = 15 mm (0,6") 45° = 5 mm (0,2")		
Tomography exposure times (in sec.)	<u>Angle</u>	<u>1<sup>st</sup> speed</u>	<u>2<sup>nd</sup> speed</u>	<u>3<sup>rd</sup> speed</u>	<u>4<sup>th</sup> speed</u>
	7°	0,6	0,5	0,4	0,3
	20°	1,8	1,3	1,0	0,9
	30°	2,6	2,0	1,6	1,3
	45°	4,0	3,0	2,4	2,0

## Stitching (option)

Stitching function	The stitching function allows the acquisition of a series of images of a wide anatomic part, which are then joined together in a single image in an automatic process. This function is typically used for full leg and full spine exams. Stitching function is available on Apollo in configuration with Villa DR acquisition systems based on wireless 35x43 cm and 43x43 cm Flat Panel detectors
Number of steps	2, 3, or 4, selected by the user
Step length	35 cm or 43 cm according to the detector orientation
Reconstructed image size	2 steps: 43x60 cm, 3 steps: 43x90 cm, 4 steps: 43x120 cm
Directions	Right-left or left-right, selected by the user
Focus distance	Can be set at installation: 140 cm to 180 cm (150 cm for SID 150 cm model)
Accessories	Stitching package includes a radiopaque ruler and an arm support for exam in lateral projection



## Accessories

2 handgrips	Standard. They can be fixed in any position along the tabletop
Footrest	Standard. It can be fixed along the tabletop every 100 mm (4") steps
Head and shoulder rest	Option. It can be fixed in any position along the tabletop
Couple of urological / gynecological leg supports	Option. They can be fixed in any position along the tabletop
Compression band	Option. It can be fixed in every position along the tabletop
Lateral cassette support	Option (only with optional overhead tube support). It can be fixed in any position along the tabletop
In-room control console	Option. Complete in-room console on mobile trolley, used to control table movements

## Safeties

Collision	All movement are software controlled to avoid collision of any part of the equipment with room floor, ceiling or walls. Room size can be set by software
Single fault	A dedicated microprocessor checks all the operating conditions of the equipment in real time and stops the operation in case of a single failure that might cause unwanted or excessive movements or radiation
Single fault hardware	A circuit disconnects the power from electrical motors in absence of command
High voltage cables	HV cables are fully integrated in the column and are completely invisible and protected with covers
Compressor parking	When not in use, the compressor is automatically parked behind the tube for maximum safety

## Electrical features

Power supply voltage	Three phase 380-400 Vac $\pm 10\%$ Three phase 415-480 Vac $\pm 10\%$ (for USA version)
Frequency	50/60 Hz
Absorbed current	Approx. 7A @ 380-400 Vac Approx. 6A @ 415-480 Vac
Absorbed power	6 kVA
Equipment type and classification according to IEC 60601-1	Class I with type B applied parts
Degree of protection according to IEC 60529	IP00
Operating mode	Continuous







## Environmental conditions

Operating conditions	Temperature: from +10° to +40° Celsius (50° F to 104° F) Humidity: from 30% to 75% Pressure: from 700 to 1060 hPa
Conditions for transport and storage	Temperature: from -20° to +70° Celsius (-4° F to 158° F) Humidity: up to 95% non condensing Pressure: > 630 hPa

## Mechanical features

	Size (W x D x H)	Weight
Table with 150 cm SID (minimum dimensions with 9" I.I.)	242 x 193 x 188 cm (95,3" x 75,9" x 74")	1155 kg (2550 lb) (Table only, without I.I., tube, accessories, cables, floor plate)
Table with 180 cm SID (minimum dimensions with 9" I.I.)	242 x 193 x 207,5 cm (95,3" x 75,9" x 81,7")	1155 kg (2550 lb) (Table only, without I.I., tube, accessories, cables, floor plate)
Electronics cabinet	52 x 55 x 195 cm (20,5" x 21,6" x 76,8")	145 kg (320 lb)
Touch screen console	36 x 36 x 12,5 cm (14,2" x 14,2" x 4,9")	< 5,2 kg (11,5 lb)
Minimum ceiling height for 90/90° tilting	265 cm (104,3") (minimum SID, SFD at the centre of table, 0° column tilt)	

## Standards and regulations

 0051	CE symbol grants the product compliance to the European Directive for Medical Devices 93/42/EEC and its revised versions as a class IIB device
<b>Additional standards for units installed in North America:</b>	
	c-MET-us approval means that the product meets the requirements of the applicable US and Canadian standards



### Dimensions for version with 150 cm SID (mm & Inches)

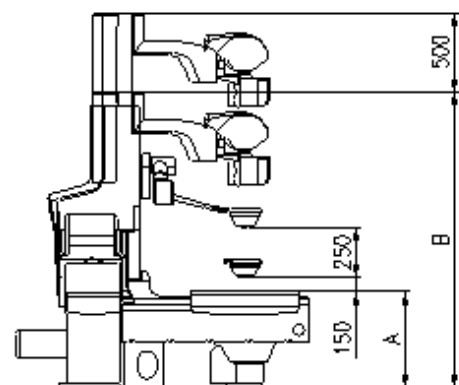
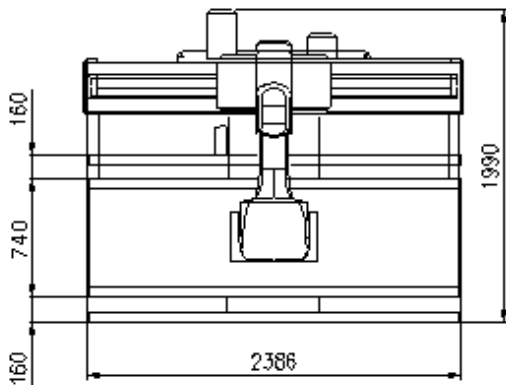
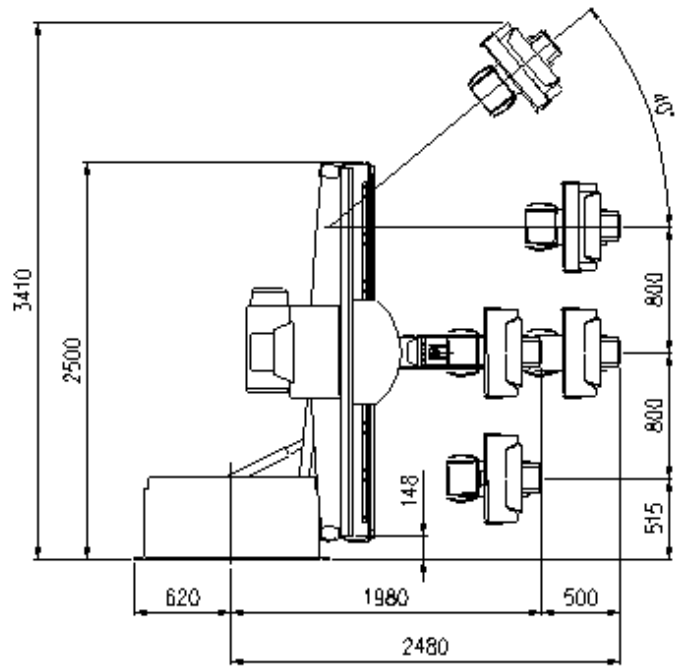
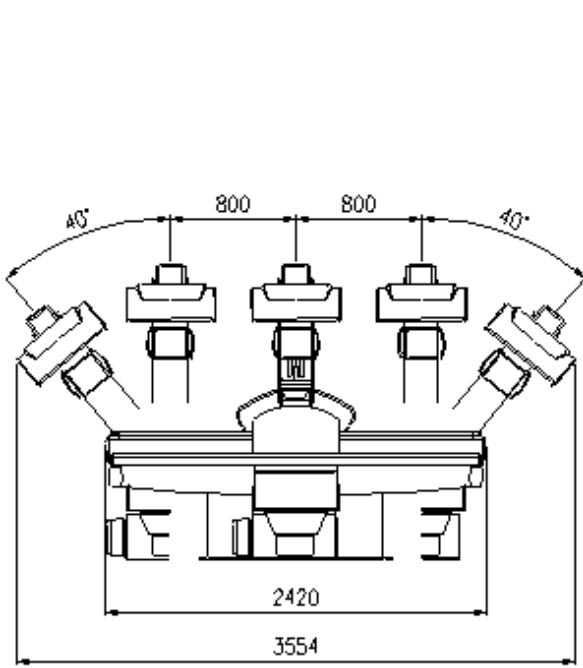

- A: with 9" i.l. min. 65,5 cm (25.8") – max 131,5 cm (51.8")  
 with 12" i.l. min. 76,5 cm (30.1") – max 131,5 cm (51.8")  
 with 16" i.l. min. 81,5 cm (32.1") – max 131,5 cm (51.8")
- B: with 9" i.l. min. 187,5 cm (73.8") – max 237,5 cm (93.5")  
 with 12" i.l. min. 197 cm (77.6") – max 237,5 cm (93.5")  
 with 16" i.l. min. 205 cm (80.7") – max 237,5 cm (93.5")

NOTE: Above measures are valid for installation with standard under-floor plate



## Dimensions for version with 180 cm SID (mm & Inches)

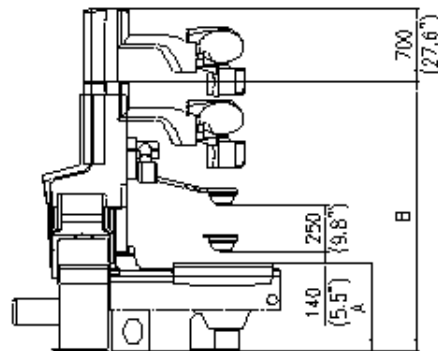
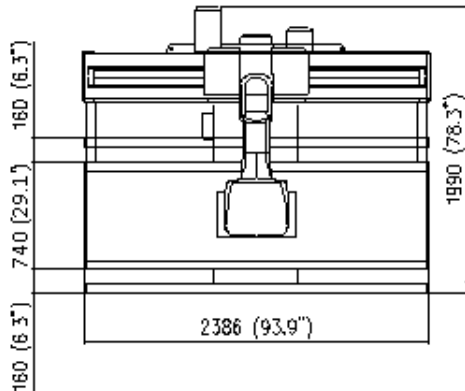
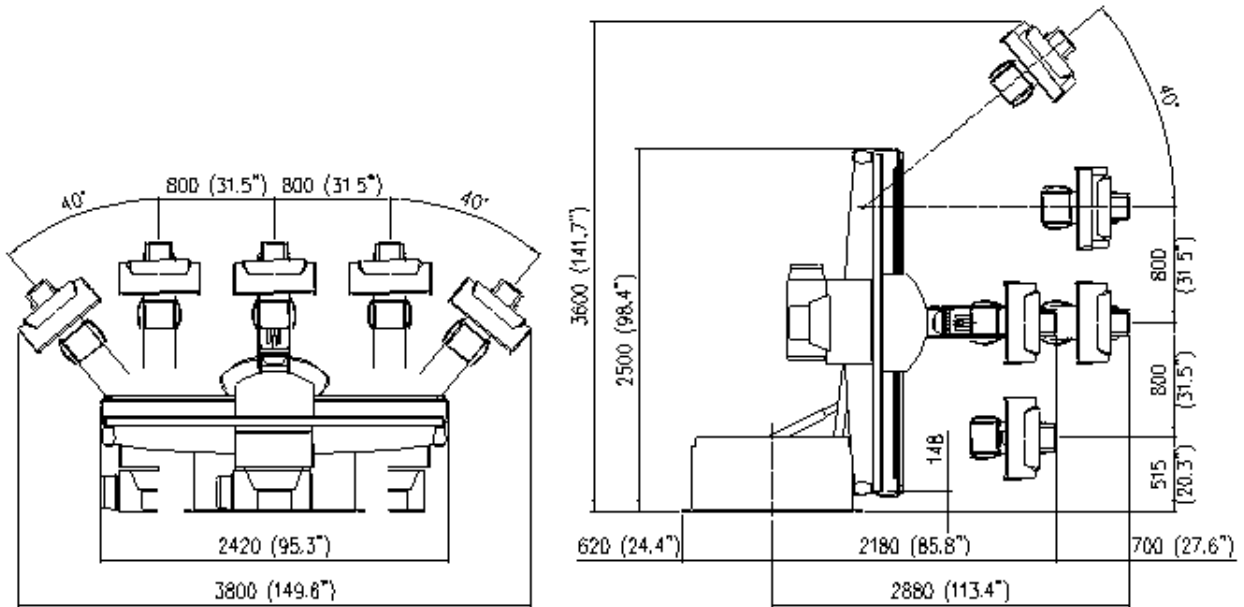







- A: with 9" I.I. min. 65,5 cm (25.8") – max 131,5 cm (51.8")  
 with 12" I.I. min. 76,5 cm (30.1") – max 131,5 cm (51.8")  
 with 16" I.I. min. 81,5 cm (32.1") – max 131,5 cm (51.8")
- B: with 9" I.I. min. 207,5 cm (81.7") – max 277,5 cm (109.3")  
 with 12" I.I. min. 217 cm (85.4") – max 277,5 cm (109.3")  
 with 16" I.I. min. 225 cm (88.6") – max 277,5 cm (109.3")

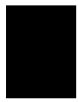

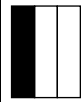



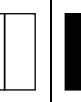
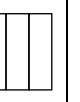
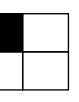

NOTE: Above measures are valid for installation with standard under-floor plate

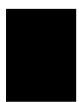

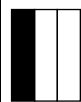
### Cassette divisions for cm size cassettes

										
13x18	X				X					
18x24	X	X		X	X	X				
24x24	X	X		X						
24x30	X	X			X	X	X		X	X
30x30	X	X	X							
18x43	X				X	X	X			
15x40	X				X	X	X	X		
20x40	X	X			X	X	X	X		
30x35	X	X	X		X	X	X			
30x40	X	X	X		X	X	X	X		
35x35	X	X	X							
35x43	X	X	X		X	X	X	X		

### Cassette divisions for inch size cassettes

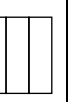
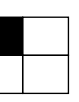
										
5x7	X				X					
8x10	X	X		X	X	X				
10x12	X	X			X	X	X		X	X
9.5x9.5	X	X	X							
7x17	X				X	X	X	X		
11x14	X	X	X		X	X	X	X		
14x14	X	X	X							
14x17	X	X	X		X	X	X			

Note: the spot film device accepts wireless Flat Panel detectors with 35x43 cm (14"x17") and 43x43 cm (17"x17") formats. The divisions are not available when using the wireless detector.

**Note:** Products are continuously under review in the light of technical improvements. The actual specification may therefore be subject to improvement or modification without notice.